



Engineering Drawings

FM-1050 Series Flowmeter (in/cm)

NUMBER OF TUBES	A		B	
	in	cm	in	cm
1	1.00	2.54	1.25	3.17
2	2.00	5.08	2.25	5.71
3	3.00	7.62	3.25	8.25
4	4.00	10.16	4.25	10.79

CONNECTIONS	C	
	in	cm
1/8" Female NPT	0.63	1.60
1/4" Female NPT	0.74	1.88
1/8" Tube Fitting*	1.33	3.38
1/4" Tube Fitting*	1.38	3.51
1/4" Hose (3/16"-3/8" Tapered)	1.78	4.52
1/8" Hose	1.30	3.30

*Dimension includes nut – hand tight (not at full compression)

VALVE OPTIONS	D	
	in	cm
Utility Valve (Full Open)	1.25	3.18
High Accuracy (Full Open)	1.80	4.57

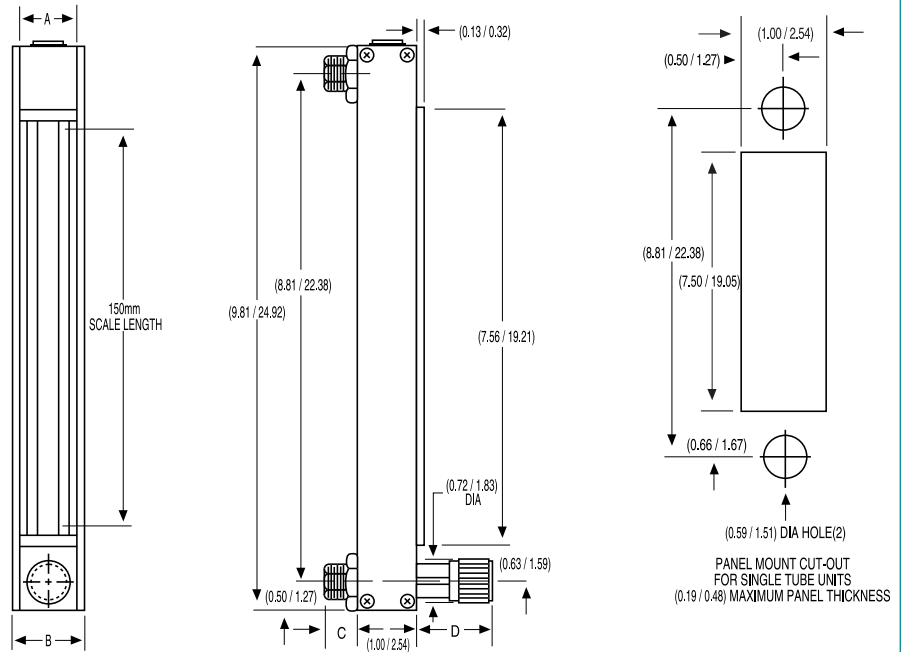

FM-1000 Series Flowmeter (in/cm)

NUMBER OF TUBES	A		B	
	in	cm	in	cm
1	1.00	2.54	1.25	3.17
2	2.00	5.08	2.25	5.71
3	3.00	7.62	3.25	8.25
4	4.00	10.16	4.25	10.79

CONNECTIONS	C	
	in	cm
1/8" Female NPT	0.63	1.60
1/4" Female NPT	0.74	1.88
1/8" Tube Fitting*	1.33	3.38
1/4" Tube Fitting*	1.38	3.51
1/4" Hose (3/16"-3/8" Tapered)	1.78	4.52
1/8" Hose	1.30	3.30

*Dimension includes nut – hand tight (not at full compression)

VALVE OPTIONS	D	
	in	cm
Utility Valve (Full Open)	1.25	3.18
High Accuracy (Full Open)	1.80	4.57

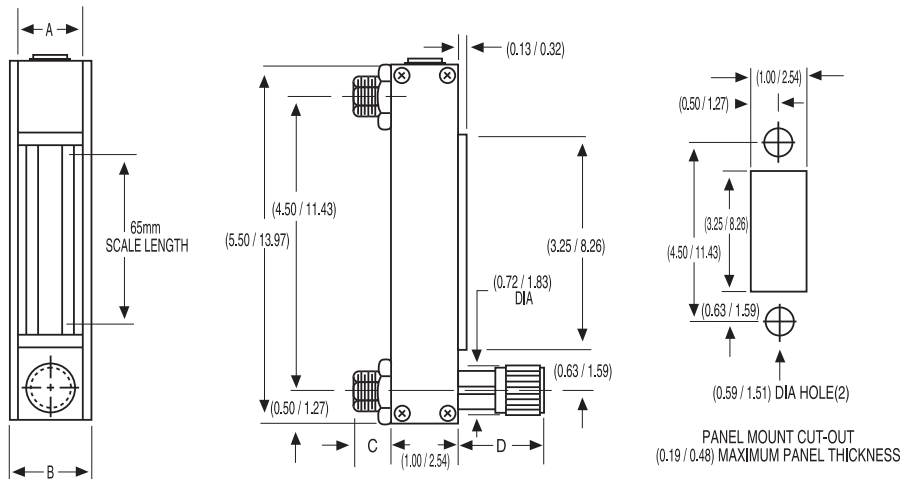

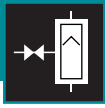

Rotameters

Engineering Drawings (continued)

FM-1100 Series and FM-1127 Series Flowmeter (in/cm)

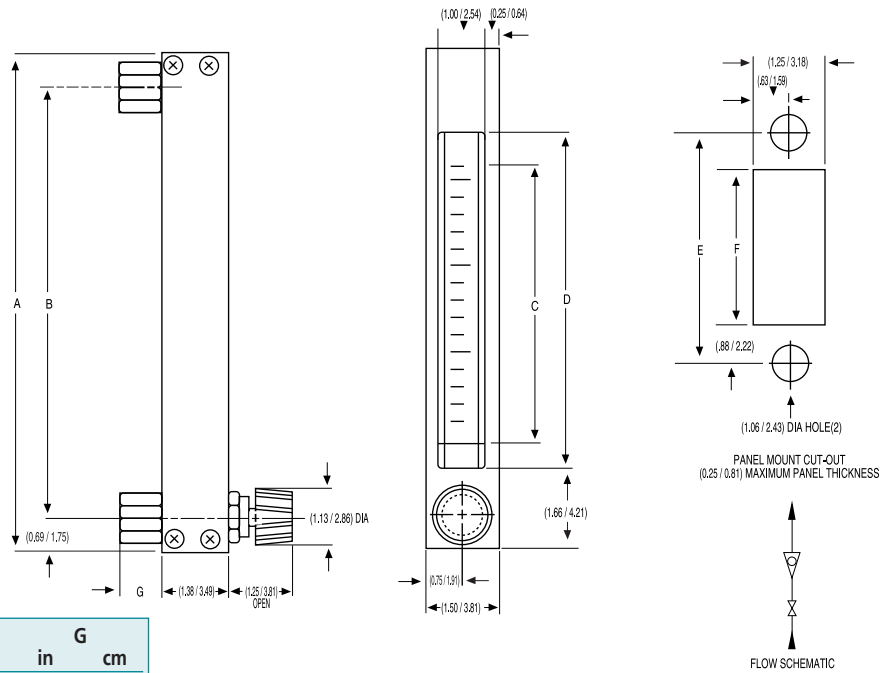

CONNECTIONS	G	
	in	cm
1/4" Female NPT*	1.75	4.45
3/8" Female NPT	0.88	2.24
1/2" Female NPT**	2.25	5.72

*Includes 3/8" FNPT - 1/4" FNPT adapter
 **Includes 3/8" FNPT - 1/2" FNPT adapter

MODEL NO.	A		B		C mm	D		E		F	
	in	cm	in	cm		in	cm	in	cm	in	cm
FM-1100	8.38	21.27	7.00	17.78	70mm scale	5.00	12.70	7.00	17.78	5.25	13.35
FM-1127	10.38	26.35	9.00	22.86	127mm scale	7.00	17.78	9.00	22.86	7.25	18.41

FLOW SCHEMATIC



Engineering Drawings (continued)

PG-1000 Series Flowmeter (in/cm)

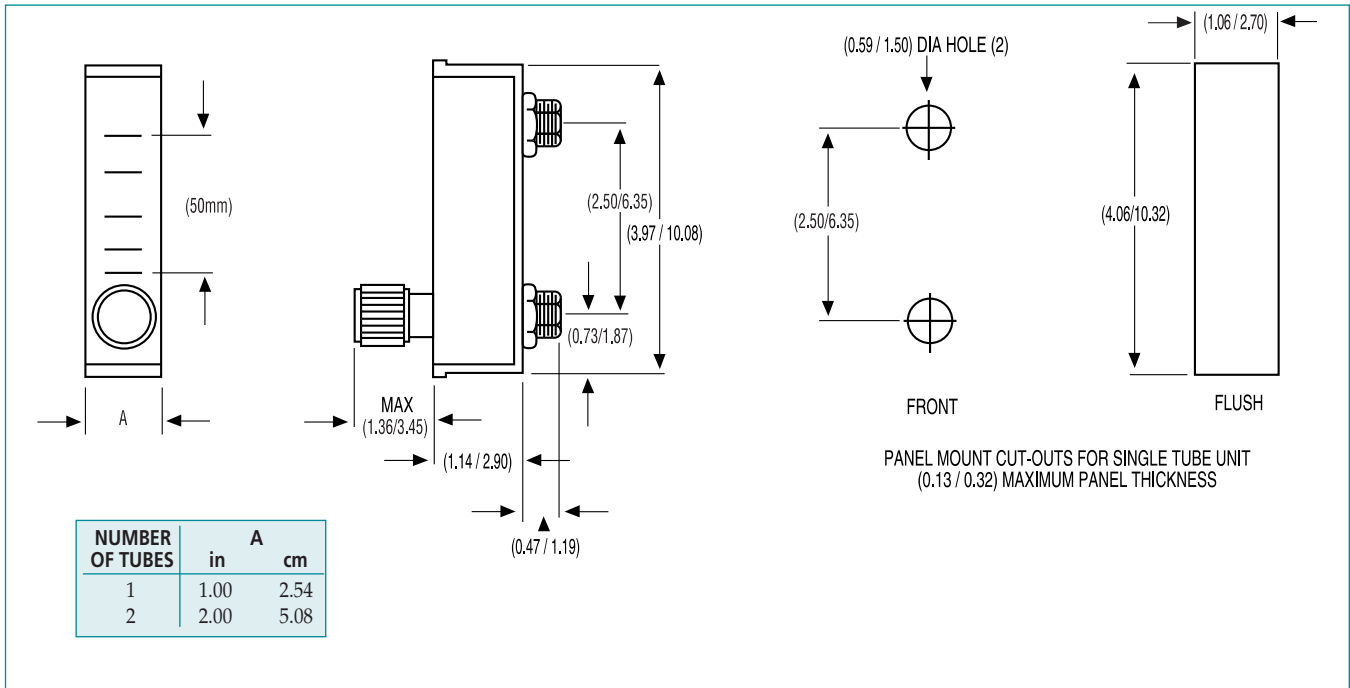

PM-1000 Series Flowmeter (in/cm)

